



Type 3 Tag Operation

Technical Specification

NFC Forum™

NFCForum-TS-Type-3-Tag_1.0

2007-08-16

RESTRICTIONS ON USE

This specification is copyright © 2005-2007 by the NFC Forum, and was made available pursuant to a license agreement entered into between the recipient (Licensee) and NFC Forum, Inc. (Licensor) and may be used only by Licensee, and in compliance with the terms of that license agreement (License). If you are not the Licensee, you are not authorized to make any use of this specification. However, you may obtain a copy at the following page of Licensor's Website: http://www.nfc-forum.org/resources/spec_license after entering into and agreeing to such license terms as Licensor is then requiring. On the date that this specification was downloaded by Licensee, those terms were as follows:

1. LICENSE GRANT.

Licensor hereby grants Licensee the right, without charge, to copy (for internal purposes only) and share the Specification with Licensee's members, employees and consultants (as appropriate). This license grant does not include the right to sublicense, modify or create derivative works based upon the Specification.

2. NO WARRANTIES.

THE SPECIFICATION IS PROVIDED "AS IS", WITHOUT WARRANTY OF ANY KIND, EXPRESS OR IMPLIED, INCLUDING BUT NOT LIMITED TO WARRANTIES OF MERCHANTABILITY, FITNESS FOR A PARTICULAR PURPOSE, ACCURACY, COMPLETENESS AND NONINFRINGEMENT OF THIRD PARTY RIGHTS. IN NO EVENT SHALL LICENSOR, ITS MEMBERS OR ITS CONTRIBUTORS BE LIABLE FOR ANY CLAIM, OR ANY DIRECT, SPECIAL, INDIRECT OR CONSEQUENTIAL DAMAGES, OR ANY DAMAGES WHATSOEVER RESULTING FROM LOSS OF USE, DATA OR PROFITS, WHETHER IN AN ACTION OF CONTRACT, NEGLIGENCE OR OTHER TORTIOUS ACTION, ARISING OUT OF OR IN CONNECTION WITH THE USE OR PERFORMANCE OF THE SPECIFICATION.

3. THIRD PARTY RIGHTS.

Without limiting the generality of Section 2 above, LICENSOR ASSUMES NO RESPONSIBILITY TO COMPILE, CONFIRM, UPDATE OR MAKE PUBLIC ANY THIRD PARTY ASSERTIONS OF PATENT OR OTHER INTELLECTUAL PROPERTY RIGHTS THAT MIGHT NOW OR IN THE FUTURE BE INFRINGED BY AN IMPLEMENTATION OF THE SPECIFICATION IN ITS CURRENT, OR IN ANY FUTURE FORM. IF ANY SUCH RIGHTS ARE DESCRIBED ON THE SPECIFICATION, LICENSOR TAKES NO POSITION AS TO THE VALIDITY OR INVALIDITY OF SUCH ASSERTIONS, OR THAT ALL SUCH ASSERTIONS THAT HAVE OR MAY BE MADE ARE SO LISTED.

4. TERMINATION OF LICENSE.

In the event of a breach of this Agreement by Licensee or any of its employees or members, Licensor shall give Licensee written notice and an opportunity to cure. If the breach is not cured within thirty (30) days after written notice, or if the breach is of a nature that cannot be cured, then Licensor may immediately or thereafter terminate the licenses granted in this Agreement.

5. MISCELLANEOUS.

All notices required under this Agreement shall be in writing, and shall be deemed effective five days from deposit in the mails. Notices and correspondence to the NFC Forum address as it appears below. This Agreement shall be construed and interpreted under the internal laws of the United States and the Commonwealth of Massachusetts, without giving effect to its principles of conflict of law.

NFC Forum, Inc.
401 Edgewater Place, Suite 600
Wakefield, MA, USA 01880

Contents

| | | |
|----------|---|-----------|
| 1 | Introduction..... | 1 |
| 1.1 | Objectives..... | 1 |
| 1.2 | Purpose..... | 1 |
| 1.3 | Applicable Documents or References..... | 1 |
| 1.4 | Administration..... | 1 |
| 1.5 | Special Word Usage..... | 1 |
| 1.6 | Name and Logo Usage..... | 2 |
| 1.7 | Intellectual Property..... | 2 |
| 1.8 | Glossary..... | 2 |
| 1.9 | Convention and notations..... | 4 |
| 1.9.1 | Representation of numbers..... | 4 |
| 2 | Memory Structure and Management..... | 5 |
| 2.1 | Blocks..... | 5 |
| 2.2 | Services..... | 5 |
| 2.3 | System Information..... | 5 |
| 2.3.1 | Manufacturer ID Information..... | 5 |
| 2.3.2 | System Definition Information..... | 6 |
| 2.3.3 | Service Definition Information..... | 7 |
| 3 | RF Interface..... | 8 |
| 4 | Framing and Transmission handling..... | 9 |
| 4.1 | Frame structure..... | 9 |
| 4.2 | Communication protocol..... | 9 |
| 4.3 | Communication endpoints..... | 9 |
| 5 | Command Set..... | 10 |
| 5.1 | State diagram (informative)..... | 10 |
| 5.2 | Polling Command..... | 10 |
| 5.3 | Check Command..... | 10 |
| 5.3.1 | Command..... | 10 |
| 5.3.2 | Response..... | 11 |
| 5.4 | Update Command..... | 13 |
| 5.4.1 | Command..... | 13 |
| 5.4.2 | Response..... | 14 |
| 5.5 | Block List..... | 15 |
| 5.5.1 | Block List Format..... | 15 |
| 5.6 | Status-flags..... | 16 |
| 5.6.1 | Status-flag1..... | 16 |
| 5.6.2 | Status-flag2..... | 16 |
| 6 | NDEF Detection and Access..... | 17 |
| 6.1 | NDEF management data..... | 17 |
| 6.1.1 | System Code..... | 17 |
| 6.1.2 | Attribute Information Block..... | 17 |
| 6.1.3 | Versioning..... | 19 |
| 6.2 | NDEF storage..... | 20 |
| 6.3 | Life cycle..... | 21 |
| 6.4 | Command sequence description..... | 22 |
| 6.4.1 | NDEF detection..... | 22 |

| | | |
|-------|-------------------------|----|
| 6.4.2 | Read NDEF message..... | 23 |
| 6.4.3 | Write NDEF message..... | 24 |
| 6.4.4 | State changes | 25 |

Figures

| | | |
|------------|--|----|
| Figure 1: | Manufacturer ID..... | 5 |
| Figure 2: | Maximum Response Time Parameter | 6 |
| Figure 3: | Type 3 Tag state diagram..... | 10 |
| Figure 4: | Block Data | 13 |
| Figure 5: | Two Bytes Block List Element..... | 15 |
| Figure 6: | Three Bytes Block List Element..... | 15 |
| Figure 7: | Mapping of NDEF to a Type 3 Tag..... | 17 |
| Figure 8: | Data Blocks in Service..... | 18 |
| Figure 9: | Attribute Information Format | 18 |
| Figure 10: | Relation between NDEF data and blocks storing it | 21 |
| Figure 11: | Life cycle states..... | 22 |
| Figure 12: | General sequence for detecting NDEF data..... | 22 |
| Figure 13: | General Sequence for reading NDEF data..... | 24 |
| Figure 14: | General Sequence for writing NDEF data | 25 |

Tables

| | | |
|----------|---|----|
| Table 1: | Access Attributes..... | 7 |
| Table 2: | Check Command Data Structure..... | 11 |
| Table 3: | Check Response Data Structure | 12 |
| Table 4: | Update Command Data Structure..... | 13 |
| Table 5: | Update response Data Structure | 14 |
| Table 6: | Error Code List..... | 16 |
| Table 7: | Handling of the mapping document version numbers..... | 19 |
| Table 8: | NDEF Services..... | 20 |
| Table 9: | Revision History..... | 27 |

1 Introduction

This specification is part of the NFC Forum documentation about tag types that an NFC Forum device needs to support in reader/writer mode.

The Type 3 Tag implements a contactless interface that is compatible with the 212 kbps and 424 kbps modes of ISO/IEC 18092 (see [ISO/IEC 18092]).

1.1 Objectives

This specification documents how an NFC Forum Device can operate an NFC Forum Type 3 Tag. This is not a specification of the Type 3 Tag itself, but how an NFC Forum Device can make use of this tag type.

1.2 Purpose

The purpose of this specification is to document the requirements and to specify, with a set of rules and guidelines, the NFC Forum Device operation and management of a Type 3 Tag.

This specification also defines the data mapping and how the NFC Forum Device detects, reads, and writes NDEF data into the Type 3 tag platform in order to achieve and maintain interchangeability and interoperability.

1.3 Applicable Documents or References

| | |
|-----------------|--|
| [ISO/IEC 18092] | ISO/IEC 18092, Information Technology- Telecommunications and information exchange between systems- Near Field Communication - Interface and Protocol (NFCIP-1). |
| [NDEF] | “NFC Data Exchange Format (NDEF)” NFC Forum™, May 2006. |
| [RFC 2119] | S. Bradner, "Key words for use in RFCs to Indicate Requirement Levels", RFC 2119, Harvard University, March 1997. |
| [DIGPROT] | “NFC Digital Protocol Specification”, NFC Forum™, to be released |
| [ANINT] | “NFC Analog Interface Specification”, NFC Forum™, to be released |

1.4 Administration

The NFC Forum Data Exchange Format Specification is an open specification supported by the Near Field Communication Forum, Inc., located at:

401 Edgewater Place, Suite 600
Wakefield, MA, 01880

Tel.: +1 781-876-8955
Fax: +1 781-224-1239

<http://www.nfc-forum.org/>

The Devices technical working group maintains this specification.

1.5 Special Word Usage

The key words “MUST”, “MUST NOT”, “REQUIRED”, “SHALL”, “SHALL NOT”, “SHOULD”, “SHOULD NOT”, “RECOMMENDED”, “MAY”, and “OPTIONAL” in this document are to be interpreted as described in RFC 2119.

1.6 Name and Logo Usage

The Near Field Communication Forum's policy regarding the use of the trademarks *NFC Forum* and the NFC Forum logo is as follows:

- Any company MAY claim compatibility with NFC Forum specifications, whether a member of the NFC Forum or not.
- Permission to use the NFC Forum logos is automatically granted to designated members only as stipulated on the most recent Membership Privileges document, during the period of time for which their membership dues are paid.
- Member's distributors and sales representatives MAY use the NFC Forum logo in promoting member's products sold under the name of the member.
- The logo SHALL be printed in black or in color as illustrated on the Logo Page that is available from the NFC Forum at the address above. The aspect ratio of the logo SHALL be maintained, but the size MAY be varied. Nothing MAY be added to or deleted from the logos.
- Since the NFC Forum name is a trademark of the Near Field Communication Forum, the following statement SHALL be included in all published literature and advertising material in which the name or logo appears:

NFC Forum and the NFC Forum logo are trademarks of the Near Field Communication Forum.

1.7 Intellectual Property

The Type 3 Tag Operation Specification conforms to the Intellectual Property guidelines specified in the NFC Forum's Intellectual Property Right Policy, as approved on November 9, 2004 and outlined in the NFC Forum Rules of Procedures, as approved on December 17, 2004.

1.8 Glossary

Access Attribute

Indicate the access control mode like "read/write" or "read only"

Block

The smallest data unit that is applicable for writing and reading.

Block List

Set of Block List Elements used in the Check and Update commands.

Block List Element

Indicates the block number, the position of the Service within the Service Code List, and the access mode for one block

Block number

Indicates the logical position of a data block belonging to a specific Service. The NFC Forum Device uses this number to access the memory data.

IDm

Manufacturer ID. This is a 8 bytes number used for addressing a Type 3 Tags.

Little Endian

A method of recording or transmitting numerical data of more than 2 bytes, with the lowest byte placed at the beginning.

Ln

Length of the NDEF data in bytes

LSB

least significant byte

lsb

least significant bit

Manufacturer ID Information

Initial Type 3 Tag information, which consists of IDm and PMm.

MSB

most significant byte

msb

most significant bit

Nbc

Number of blocks used by the NDEF data stored on the Type 3 Tag.

Nbr

Number of blocks that can be read by the Check command at once.

Nbw

Number of blocks that can be written by the Update command at once.

NDEF

NFC Data Exchange Format

Nmaxb

Maximum number of blocks available for NDEF data on a Type 3 Tag

PMm

Manufacturer Parameter that is pre-configured by the Type 3 Tag manufacturer.

NFC Forum Device

NFC Forum compliant device. For this document the NFC Forum Device is always acting in Reader/Writer mode, which is similar to a Proximity Coupling Device (PCD) in ISO terminology.

RWflag

This flag shows whether the Type 3 Tag is “read only” or allows “read/write” access.

Service

Defines the method of accessing user blocks stored in the Type 3 Tag. A Type 3 Tag can contain more than one Service.

Service Code List

List of Service Codes that indicate which Services can be accessed

Service Definition Information

Specifies the access attributes, as well as the position and number of accessible user blocks, for a specific Service.

Status Flag

Indicates the Type 3 Tag's success/error conditions.

System Definition Information

Used for command/response sequence control between NFC Forum Device and Type 3 Tag.

It consists of Manufacturer ID Information, System Definition Information, and Service Definition Information.

Type 3 Tag

NFC Forum Type 3 compatible Tag or card or token including a contactless IC chip, which has build-in memory and memory access functions. The physical shape is not defined.

WriteFlag

Flag which indicates that the process of writing is currently ongoing or not.

1.9 Convention and notations

1.9.1 Representation of numbers

The following conventions and notations apply in this document unless otherwise stated.

- Binary numbers are represented by strings of digits 0 and 1 shown with the most significant bit (msb) left and the least significant bit (lsb) right, “b” is added at the end.
Example: 11110101b
- Hexadecimal numbers are represented using the numbers 0 - 9 and the characters A – F, an “h” is added at the end. The most significant byte (MSB) is shown on the left, the least significant byte (LSB) on the right.
Example: F5h
- Decimal numbers are represented as is (without any tailing character).
Example: 245

2 Memory Structure and Management

2.1 Blocks

The basic unit of information used in memory management is called a block. Each block has a fixed size of 16 bytes. The number of memory blocks available depends on the chip hardware. Memory blocks are not addressed directly but relative to the Service they belong to.

2.2 Services

Services are similar to files in a file system. Each Service has a number of memory blocks associated with it. Services can be addressed using their Service Code, which must be unique inside each Type 3 Tag.

2.3 System Information

Each Type 3 Tag contains management data, called System Information. The system information of a Type 3 Tag consists of the following parts:

- Manufacturer ID Information
- System Definition Information
- Service Definition Information

Manufacturer ID Information and System Definition Information are pre-assigned by the Type 3 Tag manufacturer.

2.3.1 Manufacturer ID Information

Manufacturer ID Information consists of the Manufacturer ID (IDm) and the Manufacturer Parameter (PMm). The Manufacturer ID Information cannot be deleted or re-written by users.

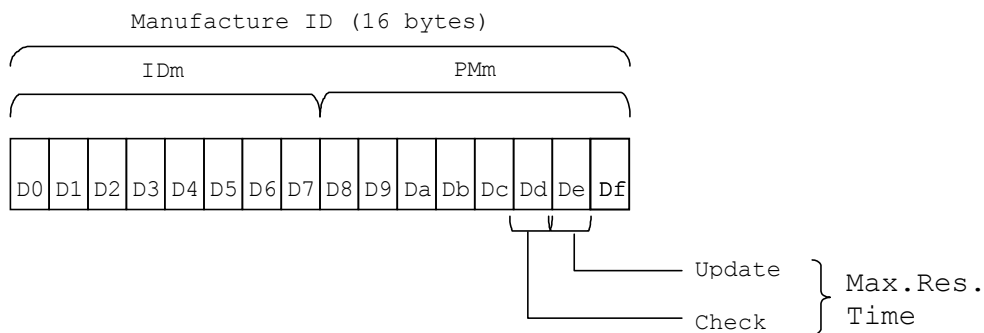

Figure 1: Manufacturer ID

2.3.1.1 Manufacturer ID (IDm)

The Manufacturer ID (IDm) is an 8 bytes number that is used by the NFC Forum device to address a Type 3 Tag.

2.3.1.2 Manufacturer Parameter (PMm)

The Manufacturer Parameter (PMm) contains the Maximum Response Time parameter.

The Maximum Response Time Parameter is used to inform the NFC Forum Device about the maximum time needed by the Type 3 Tag to execute Check and Update commands. It has a length of 6 bytes.

The NFC Forum Device SHALL interpret the 4th byte (Dd) to contain the maximum response time information for the Check command and the 5th byte (De) to contain the maximum response time information for the Update command.

The byte format for the 4th and 5th byte SHALL be interpreted as shown in the following diagram:

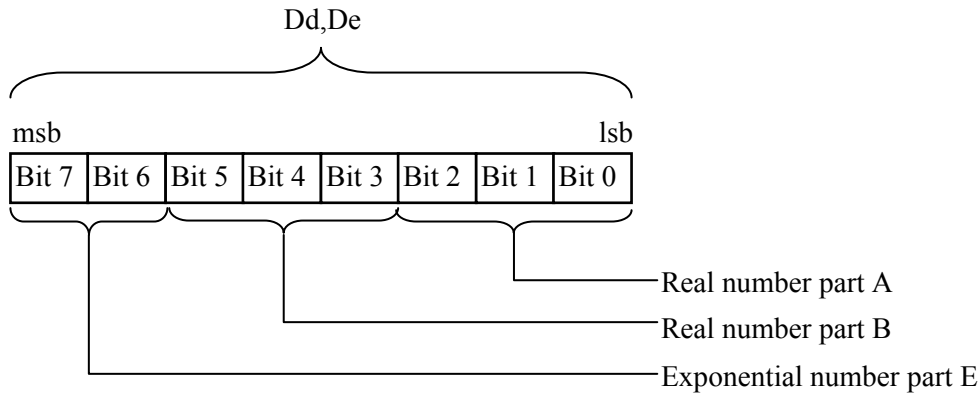

Figure 2: Maximum Response Time Parameter

The Maximum Response Time is defined by the chip manufacturer considering the maximum transaction time the Type 3 Tag needs to process the command. The response time, which is calculated using this parameter, is longer than the actual time needed for the processing of the corresponding command.

The following formula SHALL be used for the calculation of the maximum response time of the Check and Update commands:

$$\text{Maximum Response Time} = T \cdot [(B + 1) \cdot n + (A + 1)] \cdot 4^E$$

- T : 0.302 ms
- A : Real number part A
- B : Real number part B
- E : Exponential number part E
- N : Number of blocks used in the Check/Update command

The Maximum Response Time of the Polling command is fixed.

2.3.2 System Definition Information

The System Definition Information consists of the System Code.

The System Code is a 2 bytes number. NFC Forum Devices can use the corresponding parameter in the Polling command to poll targets having a specific system code.

The System Code is coded in big endian order.

2.3.3 Service Definition Information

A Service Definition Information is present for each Service existing on a Type 3 Tag. It consists of the Service Code and the Number of Blocks for the Service.

The Service Code is uniquely identifying the Service on a Type 3 Tag. It has a length of 2 bytes. The format is little endian.

The Service Code consists of a Service Number and an Access Attribute. The Service Number has a length of 10 bits (the 10 most significant bits of the 2 bytes) and is unique for each Service of a Type 3 Tag. The Access Attribute has a length of 6 bits (the 6 least significant bytes) and specifies the permissions for accessing the associated memory blocks.

The Access Attribute SHALL be interpreted as described in the table below:

Table 1: Access Attributes

| Value | Access Attribute | Comment |
|---------|------------------|--------------------------------|
| 001001b | Read/Write | Data can be read or written. |
| 001011b | Read only | Only reading data is possible. |

The Number of Blocks is a 2 byte number specifying the number of memory blocks associated with this Service.

Each Service Definition Information usually references a number of memory blocks that are exclusively used by this Service. The only exceptions are Overlap Services. Overlap Services share the same memory blocks but have different Access Attributes (e.g. read only, read/write).

3 RF Interface

The RF interface of the NFC Forum Device is defined in [ANINT]. The NFC Forum Device SHALL comply with the RF interface as defined in the relevant clauses of [ANINT] for the 212/424kbps communication modes.

4 Framing and Transmission handling

4.1 Frame structure

The NFC Forum device SHALL send Check and Update commands and responses using the bit coding, character coding and frame coding defined in [DIGPROT] for NFC-F and Tag Type 3.

4.2 Communication protocol

The communication protocol SHALL be the half-duplex communication protocol defined in [DIGPROT] for the Tag Type 3.

The timeout value for the timeout mechanism of the NFC Forum device SHOULD be calculated using the maximum response time for each command, which can be derived from the information in the Manufacturer Parameter (see chapter 2.3.1.2).

4.3 Communication endpoints

The NFC Forum device and the Type 3 Tag are always the endpoints of the communication protocol described in chapter 4.1 as this protocol is a link layer protocol.

Nevertheless the exchange of commands and responses is a higher communication layer and happens between two entities capable of constructing and extracting the commands and responses.

The entity extracting the commands and constructing the responses is always part of the Type 3 Tag. The entity constructing the commands and extracting the responses may be part of the NFC Forum Device, but might also be part of a device connected via another network to the NFC Forum Device. In this case the NFC Forum Device forwards command Packet Data it received from an entity via another network to the Type 3 Tag, by encapsulating the Packet Data using the frame format described in [DIGPROT]. In a similar way, response Packet Data received from the Type 3 Tag must be send to the receiving entity by using the protocols of the other network. In this case, the NFC Forum Device does not need to interpret the data send to and received from the Type 3 Tag.

Remark: Application developers can offer a low level interface to send and receive arbitrary data to a Type 3 Tag. Such a low level interface enables a number of applications that require a remote entity to communicate with a Type 3 Tag.

5 Command Set

This chapter describes the command set of a Type 3 Tag. Additionally an informative state diagram of the Type 3 Tag is provided. These commands belong to the ‘proprietary protocol’ defined in [ISO/IEC 18092].

5.1 State diagram (informative)

This chapter shows the state diagram of a Type 3 Tag. This chapter is informative only.

A Type 3 Tag has only one state called “Mode 0”. In this state the Polling command, Check command and Update command can be received. None of these commands changes the state of the Type 3 Tag.

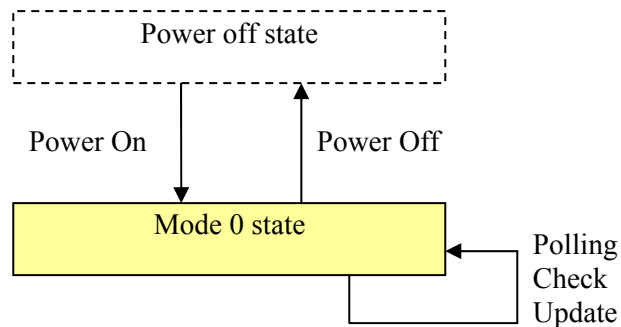

Figure 3: Type 3 Tag state diagram

5.2 Polling Command

The communication between an NFC Forum Device and a Type 3 Tag begins with the Polling command issued by the NFC Forum Device. The Polling command is used to recognize the Type 3 Tags in the field. It is also used for initialization and anti-collision.

The Polling command is fully specified in [DIGPROT] except for the following changes and additions:

- A type 3 Tag sends its IDm instead of the NFCID2 in the Polling response payload (see chapter 2.3.1.1 for information about the IDm).
- A Type 3 Tag sends its PMm instead of the Pad bytes of the Polling response payload (see chapter 2.3.1.2 for information about the PMm).

The terms Polling command and Polling response in this specification always refer to the corresponding specification given in this chapter and not to the specification in [ISO/IEC 18092] for Single Device Detection at 212 and 424 kbps.

5.3 Check Command

The Check command is used to read user data from the memory of a Type 3 Tag.

5.3.1 Command

The Command Code of the Check command SHALL be 06h.

The Check command SHALL include all data elements of the following table as command parameters:

Table 2: Check Command Data Structure

| Data Elements | Bytes | Value | Comments |
|-----------------------|---------|-------|---|
| Manufacturer ID (IDm) | 8 | | |
| Number of Services | 1 | n | It depends on the implementation of the Type 3 Tag how many Services can be read simultaneously. The minimum value is 1 and maximum is 16. |
| Service Code List | 2n | | |
| Number of Blocks | 1 | m | It depends on the implementation of the Type 3 Tag how many blocks can be read simultaneously. The minimum value is 1 and maximum is 12. |
| Block list | 2m - 3m | | See chapter 5.5 |

The Manufacturer ID (IDm) should be set to the value included in the Polling response of the targeted Type 3 tag.

The Block List SHALL be formatted as defined in chapter 5.5

The Number of Services in the Check command SHOULD be between 1 and the Maximum Number of Services (minimum value is 1 and maximum value is 16).

Every Service Code List Order value in the Block List Element SHOULD be smaller than Number of Services. The Maximum number of Service Code List Order is (n+1). The order number starts from 0 and is always smaller than Number of Services (n).

The Access Attributes of the Service Code that is specified by Block List Element SHOULD be 001001b (Read/Write) or 001011b (Read only).

The Number of Blocks in the Check command SHOULD be smaller than the Maximum Number of Blocks that is supported by the Type 3 Tag (minimum value is 1 and maximum value is 12).

All Services which are specified by the Service Code List Order in Block List Element SHOULD exist on the Type 3 Tag.

The Block number that is set in each Block List Element SHOULD be smaller than the Number of Blocks that is defined for the corresponding Service in the Service Definition Information (The maximum block number is (n+1) because the counting for this number starts from 0. This number is always smaller than Number of Blocks: n).

There MAY be Service Codes in Service Code List that are NOT referred by any of the Block List Elements in the Block List.

5.3.2 Response

NFC Forum Devices SHALL interpret responses with the response code of 07h as Check responses.

NFC Forum Devices SHALL interpret Check responses to be formatted as defined in the following table:

Table 3: Check Response Data Structure

| Data Elements | Bytes | Value | Comments |
|------------------------|-------|-------|---|
| Manufacturer ID (IDm) | 8 | | |
| Status-flag1 | 1 | | 00h: Success Others: Failure See Chapter 5.6 |
| Status-flag2 | 1 | | See Chapter 5.6 |
| Number of Blocks | 1 | m | This value is the same as Number of Blocks in the Check command. (If Status-flag1 = 00h) |
| Block Data | 16m | | (If Status-flag1 = 00h) |

The NFC Forum Device SHOULD check that the IDm in the response is the same as the one sent in the Check command. The values of Status-flag1 and Status-flag2 SHALL be interpreted according to the definition given in Chapter 5.6.

The following data is included in the response if the Status-flag1 is equal to 00h:

- the Number of Blocks is the same value as in the Check command.
- Block Data is the data read from the memory blocks specified in the Check command. The order of Block Data is the same as the order of the Block List Elements in the Block List of the Check command.

Example:

Check Command:

| Cmd. code | IDm | No. of Services | service code list | No. of Blocks | Block List | | | |
|-----------------------------------|-----------------------------------|-----------------------------------|-------------------|---------------|---|-----------------------------------|-----------------------------------|-----------------------------------|
| 06h | | 1 | 000Bh | 3 | <table border="1"> <tr> <td>Service order: 0 Block: 05h</td> <td>Service order: 0 Block: 06h</td> <td>Service order: 0 Block: 0Fh</td> </tr> </table> | Service order: 0 Block: 05h | Service order: 0 Block: 06h | Service order: 0 Block: 0Fh |
| Service order: 0 Block: 05h | Service order: 0 Block: 06h | Service order: 0 Block: 0Fh | | | | | | |

Check Response:

| Resp. code | IDm | Status-flag1 | Status-flag2 | No. of Blocks | Block Data | | | |
|----------------------------------|----------------------------------|----------------------------------|--------------|---------------|---|----------------------------------|----------------------------------|----------------------------------|
| 07h | | 0 | 0 | 3 | <table border="1"> <tr> <td>Service 000Bh, block 05h data</td> <td>Service 000Bh, block 06h data</td> <td>Service 000Bh, block 0Fh data</td> </tr> </table> | Service 000Bh, block 05h data | Service 000Bh, block 06h data | Service 000Bh, block 0Fh data |
| Service 000Bh, block 05h data | Service 000Bh, block 06h data | Service 000Bh, block 0Fh data | | | | | | |

Figure 4: Block Data

The Type 3 Tag starts sending the Check response before the end of the Maximum Response Time, which is calculated using the Maximum Response Time Parameter for the Check command in the PMm. The Maximum Response Time period starts after the Type 3 Tag has received the Check command. The timeout of the NFC Forum Device to wait for the response from the Type 3 Tag SHALL be longer than the Maximum Response Time.

5.4 Update Command

The Update command is used to write user data to the memory blocks of a Type 3 Tag.

5.4.1 Command

The Command Code of the Update command SHALL be 08h.

The Update command SHALL include all data elements of the following table as command parameters:

Table 4: Update Command Data Structure

| Data Elements | Bytes | Value | Comments |
|-----------------------|---------|-------|--|
| Manufacturer ID (IDm) | 8 | | |
| Number of Services | 1 | n | It depends on the implementation of the Type 3 Tag how many Services can be written simultaneously. The minimum value is 1 and maximum is 16. |
| Service Code List | 2n | | |
| Number of Blocks | 1 | m | It depends on the implementation of the Type 3 Tag how many blocks can be written simultaneously. The minimum value is 1 and maximum is 8. |
| Block List | 2m - 3m | | See chapter 5.5 |
| Block Data | 16m | | |

The Manufacturer ID (IDm) should be set to the value included in the Polling response of the targeted Type 3 tag.

The Number of Services in the Update command SHOULD be between 1 and the Maximum Number of Services that is supported (minimum value is 1 and maximum value is 16).

Every Service Code List Order value in Block List Element SHOULD be smaller than Number of Services. The maximum number of Service Code List Order is (n+1). The order number starts from 0 and is always smaller than Number of Services (n).

All Services that are specified by the Service Code List Order in the Block List Element SHOULD exist in the Type 3 Tag memory.

The Access Attributes of the Service Code that is specified by Block List Element SHOULD be 001001b (Read/Write) or 001011b (Read only).

The Number of Blocks in the Update command SHOULD be smaller than the Maximum Number of Blocks that are supported. (Minimum value is 1 and maximum value is 8).

The block number that is set in each Block List Element SHOULD be smaller than the Number of Blocks that is defined for the corresponding Service in the Service Definition Information. The 'Maximum number of Block' value is (n+1) because it starts from 0. This number is always smaller than Number of Blocks (n).

There MAY be Service Codes in Service Code List that are NOT referred by any of the Block List Elements in the Block List.

5.4.2 Response

NFC Forum Devices SHALL interpret responses with the response code of 09h as Update responses.

NFC Forum Devices SHALL interpret Update responses to be formatted as defined in the following table:

Table 5: Update response Data Structure

| Data Elements | Bytes | Value | Comments |
|-----------------------|-------|-------|--|
| Manufacturer ID (IDm) | 8 | | |
| Status-flag1 | 1 | | 00h: Success / Others: Failure see Chapter 5.6 |
| Status-flag2 | 1 | | see Chapter 5.6 |

The NFC Forum Device SHOULD check that the IDm in the response is the same as the one sent in the Update command.

The values of Status-flag1 and Status-flag2 SHALL be interpreted according to the definition given in Chapter 5.6.

The Type 3 Tag starts sending the Update response before the end of the Maximum Response Time, which is calculated using the Maximum Response Time Parameter for the Update command in the PMm. The Maximum Response Time period starts after the Type 3 Tag has received the Update command. The timeout of the NFC Forum Device to wait for the response from the Type 3 Tag should be longer than the Maximum Response Time.

5.5 Block List

5.5.1 Block List Format

The Block List allows specifying multiple Blocks to be accessed in one command.

The Block List SHALL consist of one or more Block List Elements. Each Block List Element indicates a block number within the Service specified by its position in the Service Code List Order.

The following figure shows the two possible structures for Block List Elements:

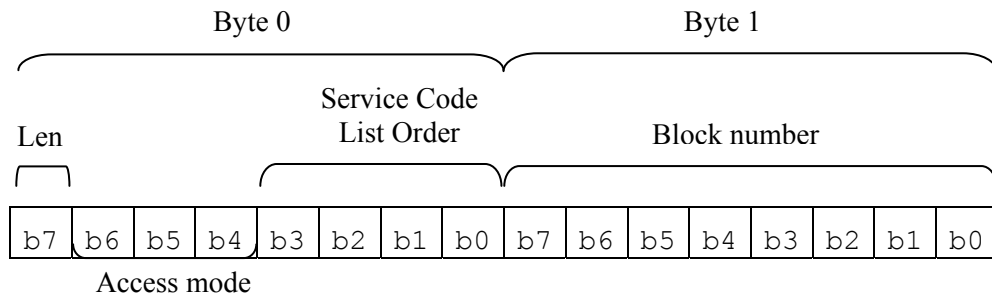

Figure 5: Two Bytes Block List Element

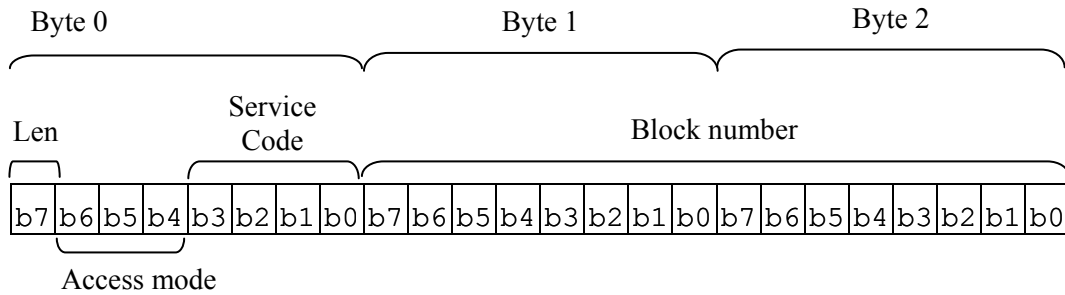

Figure 6: Three Bytes Block List Element

Block List Elements SHALL be either in a 2 byte or 3 byte format. Which format is used SHALL be specified by the Length bit which is the MSB of the first byte of each Block List Element.

The Length bit SHALL be set to 1b to indicate a 2 byte Block List Element. The Length bit SHALL be set to 0b to indicate a 3 byte Block List Element.

The bits 6, 5 and 4 of the first byte of each Block List Element are named Access Code and SHOULD be set to 000b.

The bits 3, 2, 1 and 0 of the first byte of each Block List Element are named Service Code List Order and indicate the Service the block referenced in the Block List Element belongs to. The Service Code List Order SHOULD contain the position of the corresponding Service in the Service Code List of the Check or Update commands. The first Service in the Service Code List has the number 0000b.

In case of a 2 byte Block List Element the 2nd byte SHOULD contain the block number.

In case of a 3 byte Block List Element the 2nd and 3rd byte SHOULD contain the block number in little endian format.

5.6 Status-flags

This chapter defines the allowed values of the status flags that indicate the Type 3 Tag's error conditions in a Check- or Update response.

The status is described using Status-flag1 (1 byte for indicating the error status and erroneous block) and Status-flag2 (1 byte for indicating more details of error information provided by Status Flag 1).

5.6.1 Status-flag1

The Status-flag1 is set to 00h in case the command execution was successful.

In case of an error, another value than 00h is set.

5.6.2 Status-flag2

The Status-flag2 is set to 00h in case the command execution was successful.

The values 70h and 71h indicate hardware errors of the Type 3 Tag. Any other values indicate processing errors.

Table 6: Error Code List

| Error name | Explanation | Code |
|-------------------|--|-------------|
| Memory Error | Cannot write to memory. | 70 |
| Excessive Writes | Memory has been written more than the maximum number of times. (This value depends on the hardware). | 71 |

6 NDEF Detection and Access

This section describes how an NFC Forum device can store and access NDEF records on a Type 3 Tag using the commands described in chapter 5.

The procedures described in this chapter do only apply for storing NDEF on a Type 3 Tag. They do not describe how to use the commands described in chapter 5 for other use cases.

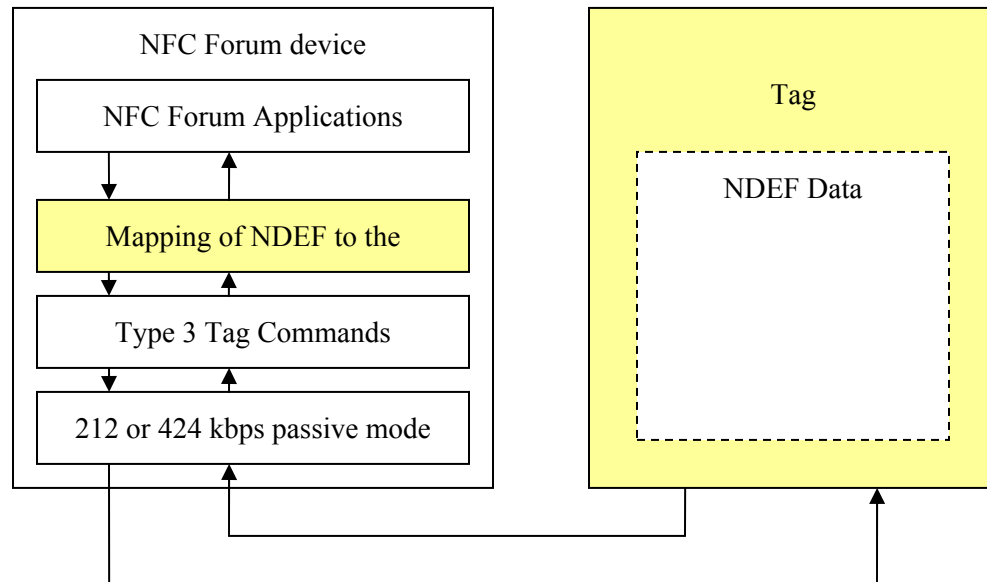

Figure 7: Mapping of NDEF to a Type 3 Tag

6.1 NDEF management data

6.1.1 System Code

The System Code 12FCh SHALL be used for NDEF enabled Type 3 Tags.

6.1.2 Attribute Information Block

The NDEF data SHALL be stored on the Type 3 Tag using the memory blocks assigned to the Service with the Service code 000Bh.

The Attribute Information Block SHALL be the 1st block of this Service. The data length is 16 bytes.

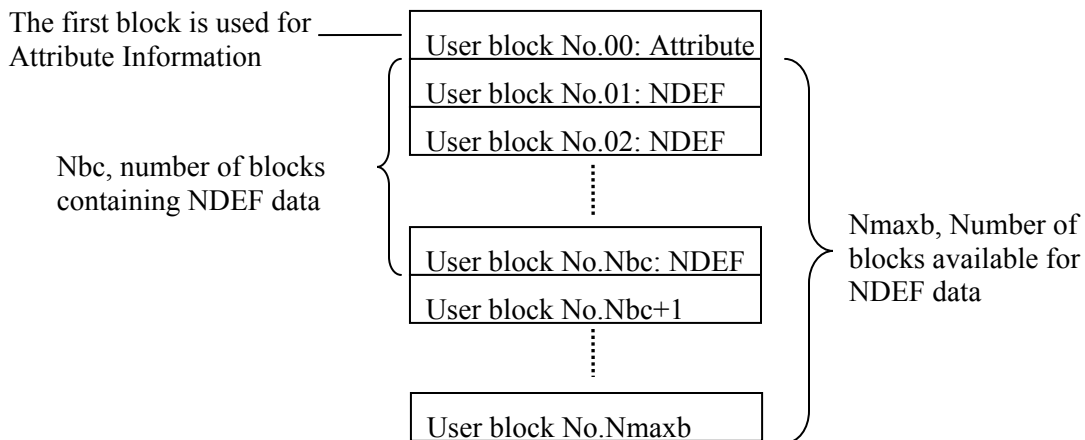

Figure 8: Data Blocks in Service

The following figure shows the structure of the Attribute Information Block:

| User Block No.00 | | | | | | | | | | | | | | | |
|------------------|--------|--------|--------|--------|--------|--------|--------|--------|--------|---------|---------|---------|---------|----------|---------|
| Byte 0 | Byte 1 | Byte 2 | Byte 3 | Byte 4 | Byte 5 | Byte 6 | Byte 7 | Byte 8 | Byte 9 | Byte 10 | Byte 11 | Byte 12 | Byte 13 | Byte 14 | Byte 15 |
| Ver | Nbr | Nbw | Nmaxb | | unused | unused | unused | unused | WriteF | RW Flag | Ln | | | Checksum | |

Figure 9: Attribute Information Format

Byte 0 SHALL be the NDEF Mapping version. The version which corresponds to this specification is 1.0. The most significant nibble (the 4 most significant bits) SHALL indicate the major version number, and the least significant nibble (the 4 least significant bits) SHALL indicate the minor version number. The NFC Forum device SHALL not change the value of this field.

Byte 1 SHALL be Nbr. Nbr indicates the number of blocks that can be read using one Check command. The NFC Forum device SHALL not change the value of this field.

Byte 2 SHALL be Nbw. Nbw indicates the number of blocks that can be written using one Update command. The NFC Forum device SHALL not change the value of this field.

Byte 3 and Byte 4 SHALL be Nmaxb. Nmaxb indicates the maximum number of Blocks available for NDEF data. Byte 3 SHALL be the upper byte, Byte 4 SHALL be the lower byte of the maximum number of Blocks. The NFC Forum device SHALL not change the value of this field.

Byte 5 to Byte 8 are currently not used and SHALL not be changed by the NFC Forum device.

Byte 9 SHALL be WriteFlag. Allowed values for the WriteFlag SHALL be:

- 00h: OFF (Writing data finished)
- 0Fh: ON (Writing data in progress)

NFC Forum Devices SHOULD set this flag to ON before writing to the Type 3 Tag and set it back to OFF after writing.

Byte 10 SHALL be RWflag. Allowed values for the RWFlag SHALL be:

- 00h: Access Attribute: Read only.
- 01h: Access Attribute: Read/Write available.

An NFC Forum Device SHALL not try to write to a Type 3 Tag with this flag set to 00h, even if writing would be technically possible. Read-only Type 3 Tags always have this value set to 00h.

An NFC Forum Device SHALL not change the value of the RWflag.

Byte 11 to Byte 13 SHALL be Ln. Ln is the actual size of the stored NDEF data in bytes. Byte 11 SHALL be the upper byte, Byte 12 SHALL be middle byte and Byte 13 SHALL be the lower byte. The number of blocks containing NDEF data (Nbc) can be calculated by the following formula $Nbc = \lceil Ln/16 \rceil$.

An NFC Forum Device SHALL update the Ln field with a correct value each time NDEF data has been written.

Byte 14 and Byte 15 SHALL be a checksum calculated using the following formula:

$$Checksum = Byte\ 0 + Byte\ 1 + \dots + Byte\ 13$$

Byte 14 SHALL be the upper byte of the checksum, Byte 15 SHALL be the lower byte of the checksum. The NFC Forum device SHALL update the checksum with a correct value every time any of the values of Bytes 0 to 13 are changed.

6.1.3 Versioning

The Byte 0 of the Attribute Information Block contains the version of the applied mapping document to the NFC Forum Type 3 Tag. The mapping document version SHALL be indicated with two numbers: major version number and minor version number.

The handling of the different mapping document version numbers applied to the Type 3 Tag (called T3VNo) and the one implemented in the NFC Forum device (called NFCDevVNo) is explained in the 4 cases of Table 7.

Table 7: Handling of the mapping document version numbers

| No | Version Number Case | Handling |
|----|---|--|
| 1 | Major NFCDevVNo is equal to major T3VNo, and minor NFCDevVNo is bigger than or equal to minor T3Vno | The NFC Forum Device SHALL access the Type 3 Tag and SHALL use all features of the applied mapping document to this Type 3 Tag. |
| 2 | If major NFCDevVNo is equal to major T3VNo, and minor NFCDevVNo is lower than minor T3Vno | Possibly not all features of the Type 3 Tag can be accessed. The NFC Forum Device SHALL use all its features and SHALL access this Type 3 Tag. |
| 3 | If major NFCDevVNo is smaller than major T3Vno | Incompatible data format. The NFC Forum Device cannot understand the Type 3 Tag data. The NFC Forum Device SHALL reject this Type 3 Tag. |

| No | Version Number Case | Handling |
|----|---|--|
| 4 | If major NFCDevVNo is bigger than major T3Vno | The NFC Forum Device might implement the support for previous versions of this specification in addition to its main version. In case the NFC Forum Device supports the previous version, it SHALL access the Type 3 Tag. On the contrary, in case the NFC Forum Device does not support the previous version, it SHALL reject the Type 3 Tag. |

Future versions of this specification have to define the allowed actions to an NFC Forum Tag with a version number lower than the version number of the NFC Forum Device (e.g. whether it is allowed to upgrade the NFC Forum Tag to the new version).

6.2 NDEF storage

The NDEF data SHALL be stored on the Type 3 Tag using the memory blocks assigned to the Service with the Service Code 000Bh.

If the Type 3 Tag allows write access to the NDEF data, the Service 0009h is available as an Overlap Service.

Table 8: NDEF Services

| Usage | Service setup |
|------------------------|---|
| NDEF is Read-Only | Service Code 000Bh is available |
| NDEF is Read/Writeable | Service Code 0009h and Service Code 000Bh are available as Overlap Services |

The first byte of Block number 1 of the Service 000Bh contains the first byte of NDEF data. If the NDEF data is larger than 16 bytes, the 17th byte of NDEF data is stored in the first byte of User block number 2. The whole NDEF data is stored on the Type 3 Tag in this way.

When the NFC Forum Device reads NDEF data, it SHALL ignore the padding if the NDEF data does not use all bytes of the last block. When the NFC Forum Device writes NDEF data to the Type 3 Tag, padding data MAY be added if the data length of the NDEF data is not a multiple of 16. Padding byte SHALL be (00h).

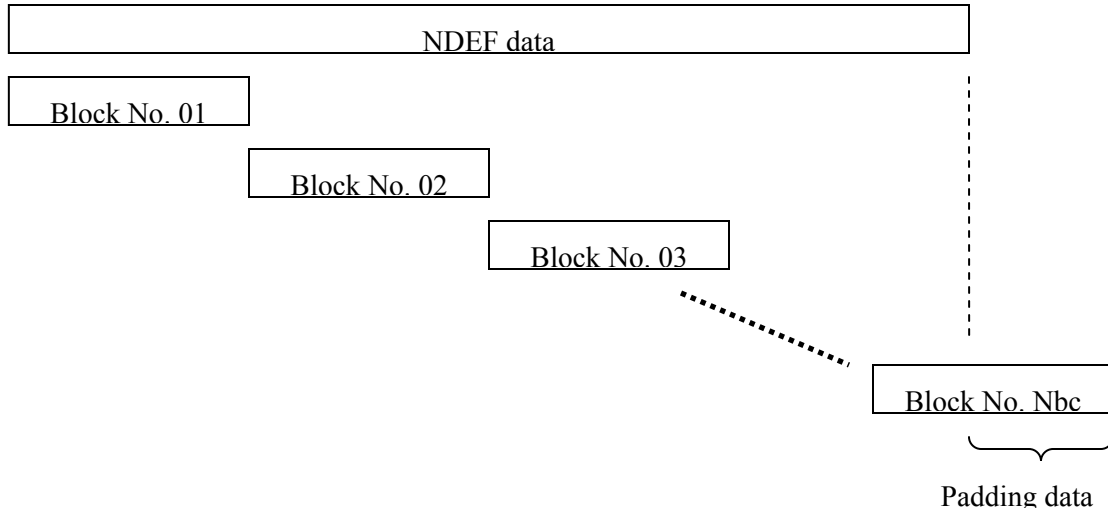

Figure 10: Relation between NDEF data and blocks storing it

6.3 Life cycle

This chapter describes the life cycle of a NDEF enabled Type 3 Tag.

An NDEF enabled Type 3 Tag may be in different states. Every state has its own valid operations.

For all states the Type 3 Tag is considered to be initialized properly for NDEF data (Service Code is 12FCh, the Service 000Bh exists and the attribute information data is initialized properly).

The NDEF enabled Type 3 Tag shall be delivered in one of the following states: INITIALISED, READ/WRITE or READ-ONLY.

The NFC Forum Device shall interpret the Type 3 Tag to be in one of the following states:

- **INITIALIZED**

The Type 3 Tag can be used to write NDEF data. The Service 0009h exists as Overlap Service. The NFC Forum device can write NDEF data using this service code. In this state, the Type 3 Tag does not contain any valid NDEF message content (Ln byte in the Attribute Information Block is 0h).

- **READ/WRITE**

The Type 3 Tag is considered to contain a valid NDEF message and be available for read/write access. The Service 0009h exists as Overlap Service. The NFC Forum device can read and write NDEF data using this service code.

This state provides the ability to read the NDEF message and also to modify, i.e. completely over-write the existing NDEF message with a new NDEF message.

- **READ ONLY**

The Type 3 Tag is considered to contain a valid NDEF message and be available for read only access. The NFC Forum device can read NDEF data using the service code 000Bh. The NDEF message cannot be deleted or overwritten with a new NDEF message. The Service 0009h does not exist.

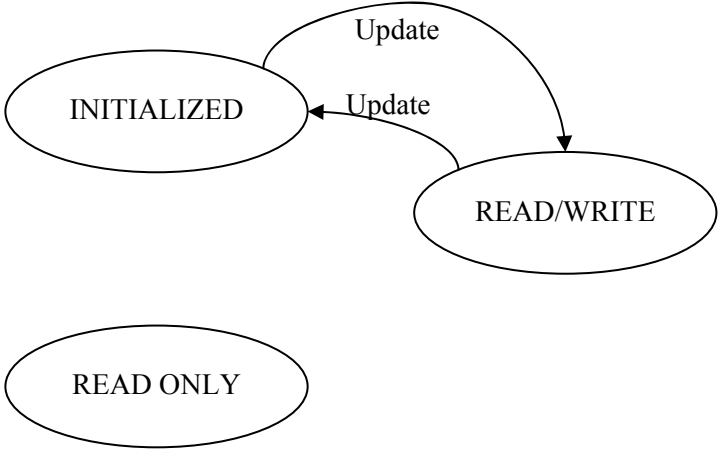

Figure 11: Life cycle states

6.4 Command sequence description

6.4.1 NDEF detection

NDEF data in the Type 3 Tag MAY be detected by an NFC Forum Device as follows:

STEP 1:

The first step to detect NDEF enabled Type 3 Tags consists of the detection of Type 3 Tags in the RF field having a System Code of 12FCh.

The NFC Forum Device sends a Polling command with System Code 12FCh. NDEF enabled Type 3 Tags respond to the Polling command by sending a Polling response including IDm and PMm.

If there is at least one Type 3 Tag with System Code 12FCh in the field, go to STEP 2, otherwise repeat STEP 1.

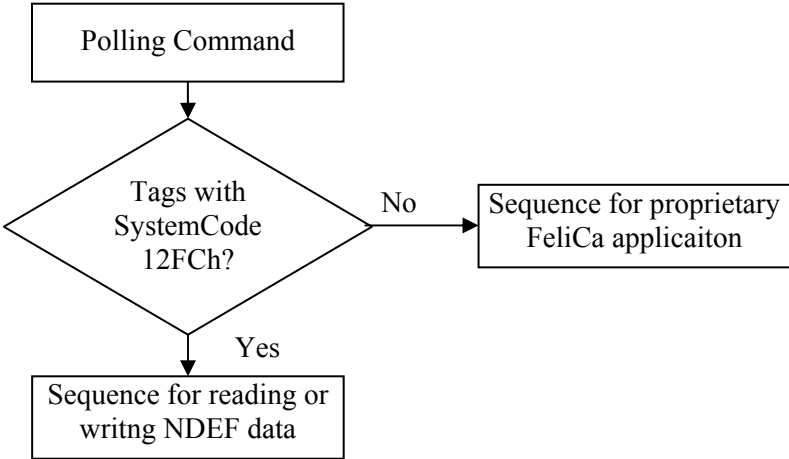

Figure 12: General sequence for detecting NDEF data

STEP 2:

If there are more than one NDEF enabled Type 3 Tags in the field the NFC Forum Device SHALL select one of them for this step. The NFC Forum Device MAY perform step 2 sequentially for each NDEF enabled Type 3 Tag.

NFC Forum Device SHALL read the Attribute Information data using the Check command. For the Check command, the NFC Forum Device SHALL use the same IDm that it received in the Polling response from the Type 3 Tag.

The Attribute Information data contains a checksum to confirm that the Attribution Information data is valid. The NFC Forum Device SHALL validate the checksum. The NFC Forum Device SHALL check if it supports the NDEF mapping version number based on the rules given in chapter 6.1.3.

If the checksum is correct and the NFC Forum Device supports the NDEF mapping version, the NFC Forum Device MAY proceed with

- The read NDEF message phase, or
- The write NDEF message phase

If the checksum is not correct or the NFC Forum Device does not support the NDEF mapping version, the NFC Forum Device SHALL not read or write NDEF data to this Type 3 Tag.

If the Attribute Information data is valid, the NFC Forum Device knows the parameters Nbr, Nrwl, Nmaxb, RWflag and Ln.

If the value of Ln is greater than 0, the Type 3 Tag contains NDEF data.

6.4.2 Read NDEF message

The purpose of this phase is to read the data blocks containing NDEF data in order to assemble the NDEF data structure stored on the Type 3 Tag.

For all commands, the NFC Forum Device SHALL use the same IDm that was used during the NDEF detection phase for the selected Type 3 Tag.

Before reading NDEF data, the NFC Forum Device MAY check if the WriteFlag is OFF which means that previous writing sequences finished correctly. Even if the WriteFlag is ON, the NDEF data on the Type 3 Tag may be valid.

NFC Forum Device SHALL read the blocks from block No. 01 until block number Nbc. Nbc SHALL be calculated as explained in chapter 6.1.2.

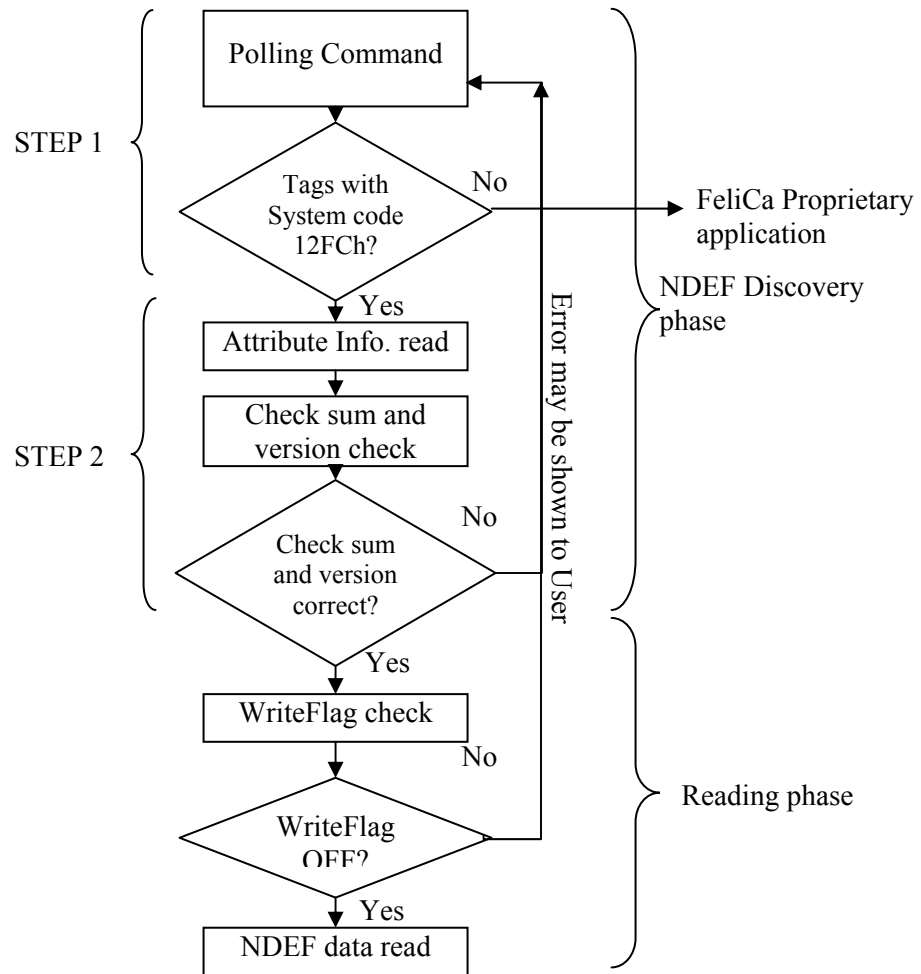

Figure 13: General Sequence for reading NDEF data

6.4.3 Write NDEF message

The purpose of this phase is to write NDEF data to a Type 3 Tag. Any existing NDEF data on the Type 3 Tag will be overwritten.

For all commands, the NFC Forum Device SHALL use the same IDm that was used during the NDEF detection phase for the selected Type 3 Tag.

The NFC Forum Device SHALL check the RWFlag and only attempt to write if its value is 01h.

Before writing NDEF data, the NFC Forum Device MAY check if the NDEF data size is smaller than the maximum memory size for NDEF data available on the Type 3 Tag. In this case the NFC Forum Device SHALL calculate the maximum memory size for NDEF by multiplying Nmaxb times 16.

Before writing NDEF data, the NFC Forum Device SHOULD update the Attribute Information with the WriteFlag set to ON.

The NFC Forum Device SHALL start writing the blocks from Block No. 01 until block number Nbc. The number of blocks to use for NDEF data (Nbc) SHALL satisfy $Nbc \leq Nmaxb$.

After writing the NDEF data, the NFC Forum Device SHALL write updated Attribute Information data to the User Block No. 00 using the Update command. The Length information within the Attribute Information SHALL be changed according to the amount of NDEF data written. The WriteFlag SHALL be set to OFF.

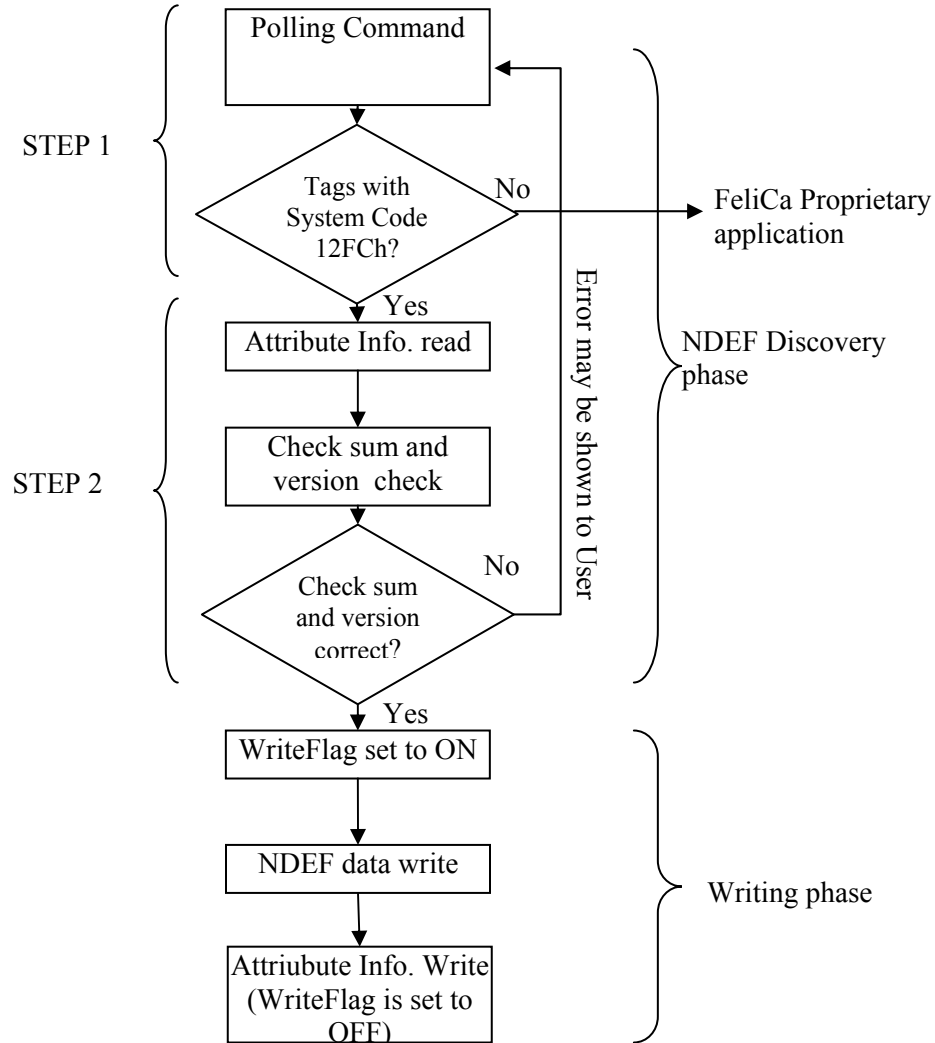

Figure 14: General Sequence for writing NDEF data

6.4.4 State changes

A state change from the 'INITIALIZED' to the 'READ/WRITE' state can be performed by writing a valid NDEF message to the Type 3 Tag as described in chapter 6.4.3.

A state change from the 'READ/WRITE' to the 'INITIALIZED' state can be performed by updating the attribute information block with an Ln value of 0.

A. Typical activation sequence

This is an informative chapter outlining the typical activation sequence from the point of view of a stand-alone NFC Forum Device implementation.

The activation sequence of a Type 3 Tag is compatible with the Initialisation and Single Device Detection used by ISO/IEC 18092 for the 212 kbps and 424 kbps modes (see [ISO/IEC 18092]).

The communication between NFC Forum Device and the Type 3 Tag is initiated as follows:

1. The NFC Forum Device switches on the RF field. The NFC Forum Device sends a Polling command. The NFC Forum Device should wait for at least 5 milliseconds after switching the RF field on before sending a polling command (Remark: According to NFCIP-1, NFC Forum Devices may need up to 2 seconds in the 212/424 kbps modes as activation time).
2. The NFC Forum Device waits to receive Polling responses from the Type 3 Tags in the field. If the NFC Forum Device fails to receive a Polling response, then the NFC Forum Device may send a Polling command again. If there was a collision when receiving the Polling responses, the NFC Forum Device should send a Polling command again.
3. Each Polling response contains the IDm information of the sending Type 3 Tag, which can be used by the NFC Forum Device as part of the Check and Update commands to further communicate with the Type 3 Tag. The NFC Forum Device may communicate with multiple Type 3 Tags using their respective IDm.

B. Revision History

The following table outlines the revision history of Type 3 Tag Operation.

Table 9: Revision History

| Document Name | Revision and Release Date | Status | Change Notice | Supersedes |
|----------------------------|----------------------------------|---------------|----------------------|-------------------|
| NFCForum-TS-Type-3-Tag_1.0 | 1.0, July 2007 | Final | None | |