

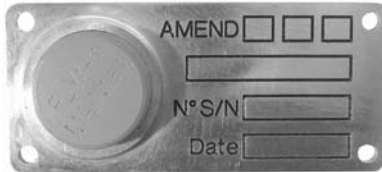

- AS5678
- ATA spec2000 ch. 9-5
- TegoChip™ 4kBytes*
- Ultra rugged



FLYtag™ Nano

Aircraft RFID tag for parts marking



- Aircraft Industry
- Maintenance, MRO
- Logistics, Asset tracking
- Supply chain
- Anti-counterfeiting



FLYtag™ Nano is a flyable UHF RFID tag based on (In Mold Airless Tagging) technology suitable to aircraft parts marking in harsh environment and on metal. FLYtag™ Nano is built around the TegoChip™ 4kbytes* high memory passive contactless UHF which supports with ISO 18000-6C, ATA spec2000 chap.9-5 and annex 11 standards. Data retention is over 30 years at 150 °C and the tag resists gamma / X-ray radiation and magnetic fields.

The ultra rugged packaging and the chip are design for extreme environments and comply with SAE AS5678 requirements and AIRBUS A350XWB specification. The extreme survival temperatures: -60°C/+150°C and pressure 194 hPa allows use in pressurized and non-pressurized areas.

Communication with the chip, including access to all of User memory, can be performed by standard Gen2 compatible readers. The FLYtag™ Nano supports all mandatory functionality and modes as defined by the ISO/IEC 18000-6 Type C (EPCglobal Gen 2) air interface specifications, including Miller encoding. Proprietary or non-standard commands are never necessary.

Applications

These tags are designed for identification, Maintenance Repair and Overhaul tracking applications in aircraft industry.



*8kbytes available end of 2010

RUGGED PACKAGED TAGS

www.maintag.com

MAINTag, 9 rue française, 75002 Paris

Tel : + 33 (0) 1 40 13 89 60 - Fax : + 33 (0) 1 40 13 02 36

© 2009 MAINTag All right reserved

FLYtag Nano – 11877 – DATASHEET – 20100110



→ AS5678

→ ATA spec2000 ch. 9-5

→ TegoChip™ 4kBytes

→ Ultra rugged

Characteristics

- Ultra Small Footprint: D14 mm.
- Reading distance: 0,1m maximum with approved handheld terminal.
- Installation area: Pressurized and non-pressurized areas.
- Standards: SAE AS5678 – ATA spec 2000 chap 9-5 Annex 11
- Air interface: Fully passive design, EPCglobal Gen 2 and ISO 18000-6C compliant. 850-960 Mhz
- Memory: 4Kbytes non-volatile memory; read and write access. Memory is configurable for different applications. (8kbytes available end of 2010) and has tamper-proof archival characteristics.
- Receive Data Rate: min 26 kbps – max 128 kbps
- Transmit Data Rate (PSK Modulation) : min 40 kbps - max 640 kbps.
- Long memory life: minimum 30 year data retention at 150°C.
- Resistant to magnetic fields and gamma / X-ray radiation without memory corruption.
- Weight: 4g +/- 0,5g (maximum, under weight reduction improvement program)
- Operational temperature: -25°C to +85°C
- Survival/Storage temperature: - 60°C to +150°C
- Material: SRP polymer 30% loaded – Elasticity module 15 000 Mpa – Shock resistance: 20 KJ/m2
- Dielectric rigidity: up to 50kV/m
- Fire: high resistance UL94 VO and ILO up to 50%
- Chemical capabilities: 0,04% low humidity absorption, hydrolysis proof, high compatibility with solvent including chlorine solutions, lubricants and hydrocarbons.
- Adhesive: 3M VHB 9473 ACRYLIC
- Color: White
- Optional devices: Aluminum bracket ref: 11880 – Aluminum name plate ref: 11881 (marking on demand)

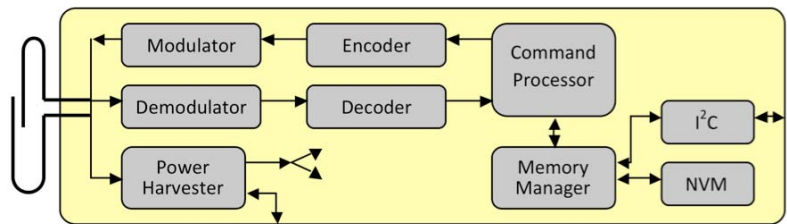

TegoChip™ functional block diagram
 NVM: Non-Volatile Memory
 I²C: Inter Integrated Circuit (not available)



ITEM	Order Code
FLYtag™ Nano 4kbytes (8kbytes available end of 2010)	11877
Optional aluminum bracket for FLYtag™ Nano	11880
Optional aluminum name plate for FLYtag™ Nano (marking on demand)	11881

Outline Drawing

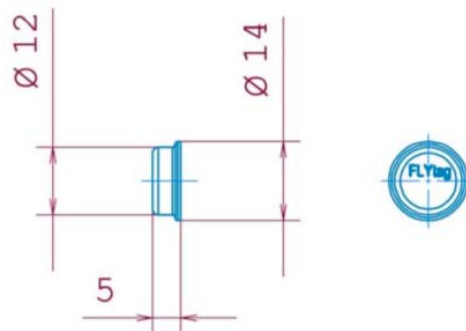

www.maintag.com

MAINTag, 9 rue française, 75002 Paris

Tel : + 33 (0) 1 40 13 89 60 - Fax : + 33 (0) 1 40 13 02 36

© 2009 MAINTag All right reserved

FLYtag Nano – 11877 – DATASHEET – 20100110



- AS5678
- ATA spec2000 ch. 9-5
- TegoChip™ 4kBytes
- Ultra rugged

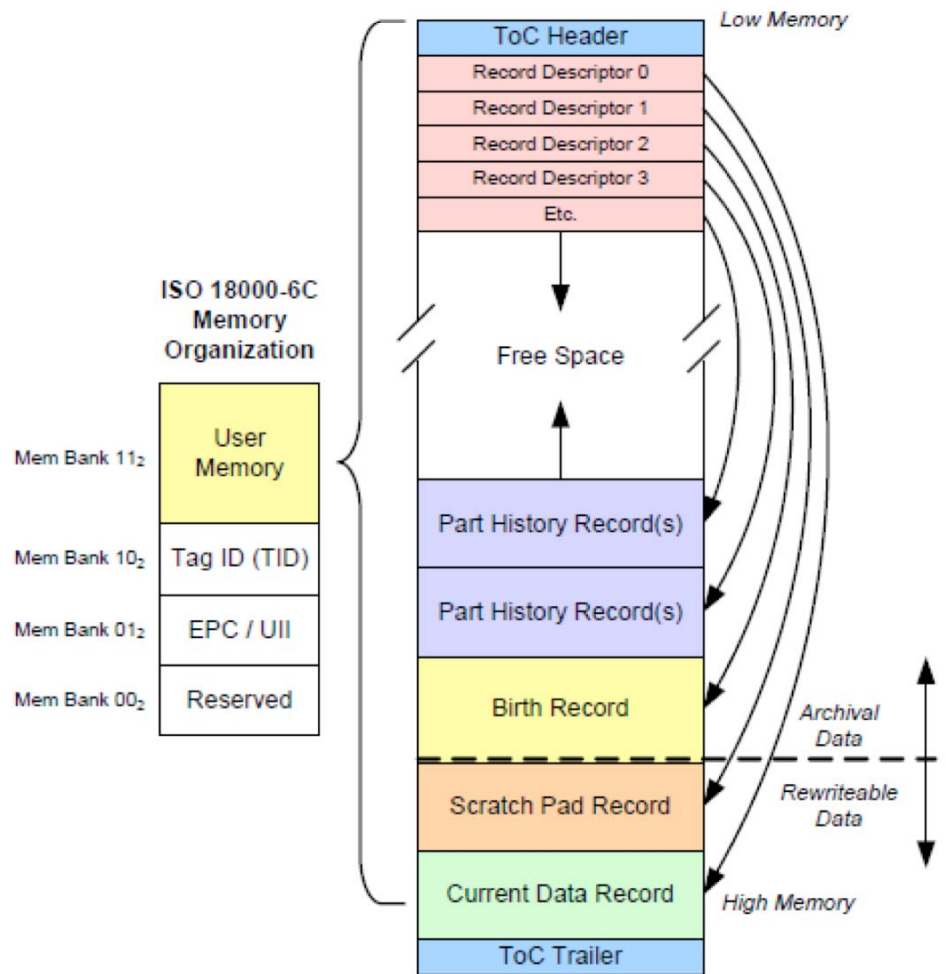

Figure extracted from ATA Spec 2000 Chap 9-5 published in 2009

The chip is perfectly suited for the ATA container structure. The device includes internal capability that makes write-once locations truly archival in that once they are written they cannot be modified, even through deliberate attempts from an interrogator. Similar in functionality to the EPC Global "permalock" behavior, archival locations are determined through device configuration and can be defined on word boundaries so that no memory locations are ever wasted. The Current Data Record, the scratchpad region and the ToC trailer are configured to re-writable locations, again on word boundaries.



- ➔ AS5678
- ➔ ATA spec2000 ch. 9-5
- ➔ TegoChip™ 4kBytes
- ➔ Ultra rugged

FLYtag Outline drawing

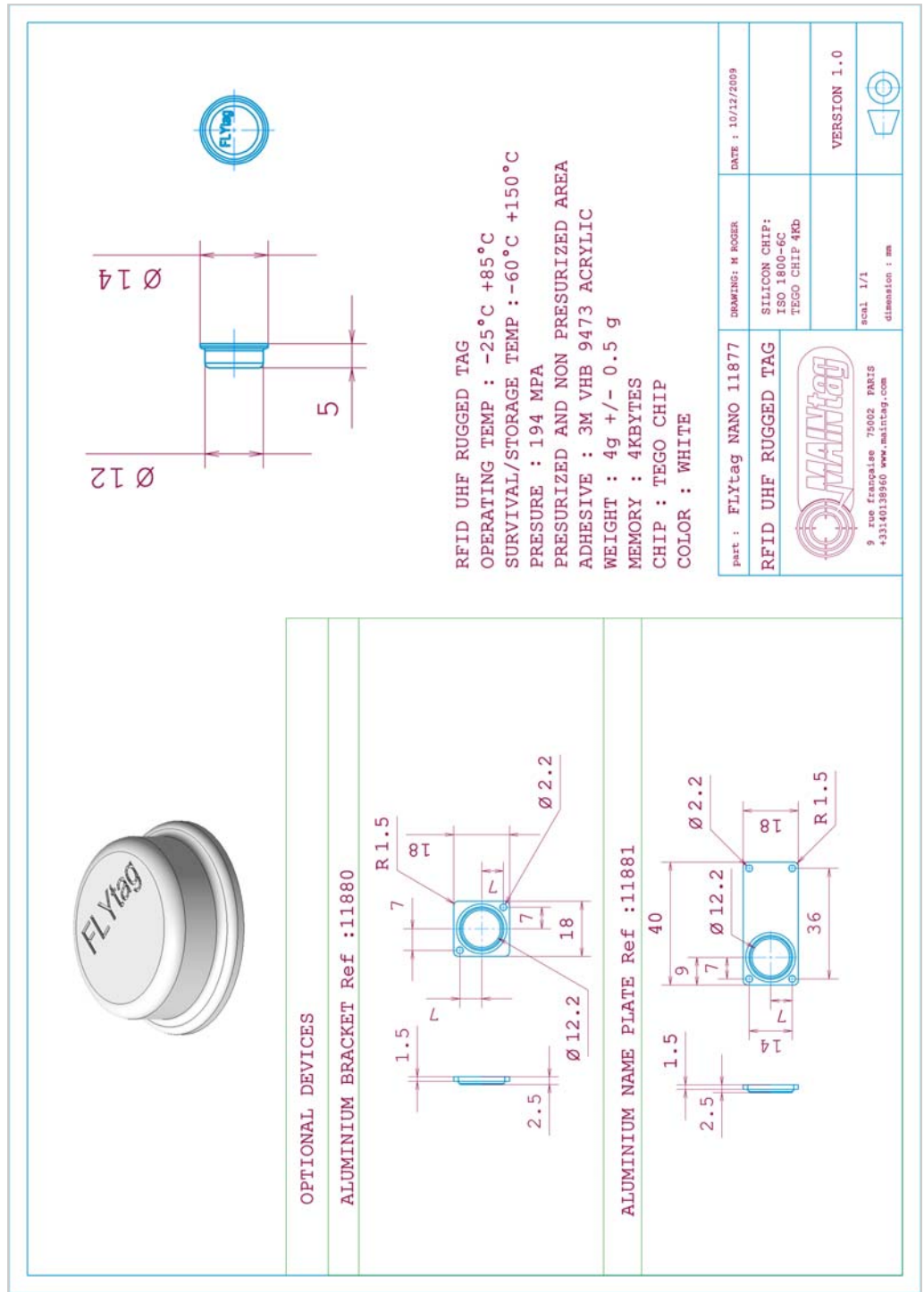

www.maintag.com

MAINTag, 9 rue française, 75002 Paris

Tel : + 33 (0) 1 40 13 89 60 - Fax : + 33 (0) 1 40 13 02 36

© 2009 MAINTag All right reserved

FLYtag Nano – 11877 – DATASHEET - 20100110